

### **Addendum Number Three**

To The Drawings and Specifications for  
Ottawa Travel Center for J&J Development  
Ottawa, Kansas

Issued: October 9, 2008

### **HANNEY & ASSOCIATES ARCHITECTS**

1726 South Hillside, Wichita, Kansas

### **NOTICE TO BIDDERS**

You are hereby instructed to include in your bids the following changes and/or corrections to the Drawings and Specifications for the new Ottawa Travel Center in Ottawa, Kansas.

The additions and/or corrections shall be considered as a part of the Contract Documents as if incorporated therein. Where the following corrections and/or additions vary from the conditions of the Drawings and Specifications, such following changes or additions shall govern.

#### **I. GENERAL CLARIFICATIONS:**

- 1.1 *The bid date shall REMAIN Friday, October 10, 2008. All bids shall be received on or before 11:00 a.m. All bids will still be received at the Owner's office as specified.*
- 1.2 The owner is waiving the requirement for bid bond and for construction (material/labor) bonding.
- 1.3 Any questions to the Architect must be submitted in writing. Please fax questions or clarification requests, along with your contact information, to Martin Hanney at 316-684-1441.
- 1.4 Acoustical fabric in the movie room 108, the black color shall be clarified to be Gilford of Maine 701-2100-408 black or the approved equal. The thickness of the installation shall be 1".
- 1.5 Video equipment by others.
- 1.6 Any reference to plastic laminate countertops in restrooms shall be changed to quartz by silestone.
- 1.7 Bowls on vanities shall be undermounted not surface mounted.
- 1.8 EIFS shall be equal to Senergy by BASF wall systems, 800.221.9255, [senergyinfo@basf.com](mailto:senergyinfo@basf.com).

## II. CHANGES TO THE DRAWINGS

### 2.1 Sheet A3.1

#### 2.1.1 Room Finish Schedule.

- 1) Room List: 115, 119, 120, 121, 122 shall have:  
M2 countertops and back splash  
Base cabinets, front panel: High wear plastic laminate
- 2) Room Finish Legend
  - a. m2 will be stellar marine
  - b. m5 will be stellar fire
- 3) Pattern O is similar to Pattern D with a change to tile 23. Tile 23 shall change to color LA88 Black Pearl PO at pattern O only.

### 2.2 Sheet A3.2/A3.1

#### 2.2.1 The following patterns shall be clarified as being used in the following areas:

- a. W33 Pattern D – Large grid in restroom 106/103 Sheet A6.8
- b. W34 Pattern E – Partitions between stalls Men 103, Women 106
- c. W36 Pattern G – Sheet A6.6/A6.9
- d. W37 Pattern H – Modified; refer to Sheet A6.9 Dtl 2 for layout
- e. W39 Pattern J – Refer to A6.9
- f. W40 Pattern K – Details reference locations
- g. W41 Pattern L – Details reference locations
- h. W42 Pattern M – Sheet A6.8: shower areas
- i. W44 Pattern P – Halls Dtl 5 on A6.6 and A6.5. Pattern P is similar to Pattern A: upper wall paint in lieu of wall covering. Color W20 changes to LA26 White Coral PO in lieu of LA63 Red Rock PO.
- j. W45 Pattern Q – Not used.

### 2.3 Sheet A3.2

#### 2.3.1 Detail A refers to “F23”. This should be changed to reference “F22”.

### 2.4 Sheet A4.3

#### 2.4.1 Elevation 2 shows doors below the bun warmer, but the section it references, 10/A7.1, indicates it should be a drawer this should be clarified to be 2 drawers at 27” wide.

### 2.5 Sheet A6.11

#### 2.5.1 Detail 4 Shower seat: Shall be

- a. 3cm thick- 1-1/4” bullnose: stellar marine
- b. Install at 1:12 slope
- c. Groove (6) 1/4” deep 1/2” wide
- d. Drain slots 2’ length, on center
- e. Provide 3/4” plywood water resistant backer board.

#### 2.5.2 Detail 13. Detail applies to Equipment 78 on Sheet A6.1: Illuminated display 48” x 48”.

- 2.6 Sheet A6.1  
2.6.1 In rooms 1005, 110, and 116, a 4' by 18' by 84 shelf may be used for the Lyon 8000 5x18x84 shelf. Lyon 8000 does not manufacture 5x18x84 shelving units.
- 2.7 Sheet A6.2  
2.7.1 Detail A, enlarged store plan. Elevation markers on game room shall be revised to indicate 13,14,15,16 on sheet A6.6 in lieu of 1-4 on sheet A6.9.
- 2.8 Sheet A6.6  
2.8.1 Details 18-21 refer to Game Room. This shall be corrected to be a Movie Room.  
2.8.2 Details 13-16 shall reference Pattern F in lieu of Pattern G.
- 2.9 Sheet A7.2  
2.9.1 Detail #10/11: checkout counter shall have siltstone counter in lieu of stainless steel.

### **III. CHANGES TO THE SPECIFICATIONS**

- 3.1 Section 06200 – Millwork  
Paragraph 8.21 item c, Shall read as follows
- 1) (m5) 3 cm thick- 1-1/4" bullnose; stellar fire  
-provide 3/4" plywood water resistant backer board
  - 2) (m4) 3 cm. Thick 1-1/2" bullnose; stellar marine  
-provide 3/4" plywood water resistant backer board.
  - 3) backsplash material m5 and m2, are to be 2 cm. thick.
- 3.2 Sections 06200 - item 8.17 detail 22  
3.2.1 approved equal for keyboard tray shall be model #KVSD14 as manufactured by Hardware distributors LTD. [www.hdlusa.com](http://www.hdlusa.com)
- 3.3 Section 10800 – Toilet Accessories  
3.3.1 Item numbers (U) ADA Shower Seat and (W) Shower Room Bench Seat are not acceptable. Approved equals are: Refer to this addendum item number 2.5 for additional information.

### **IV. CHANGES TO THE MECHANICAL**

- 4.1 Sheet M4.1  
Revise RTU-9 model number to YSC036 in lieu of YHC036.
- 4.2 Sheet M3.1  
Delete note that reads "Supply and Return ductwork shall be insulated the first 10' and wrap insulated the whole distance" from Roof Top Unit Section Detail.

Delete Air Curtain Detail.

- 4.3 All return air grilles open to plenum shall be installed with return air sound boot.

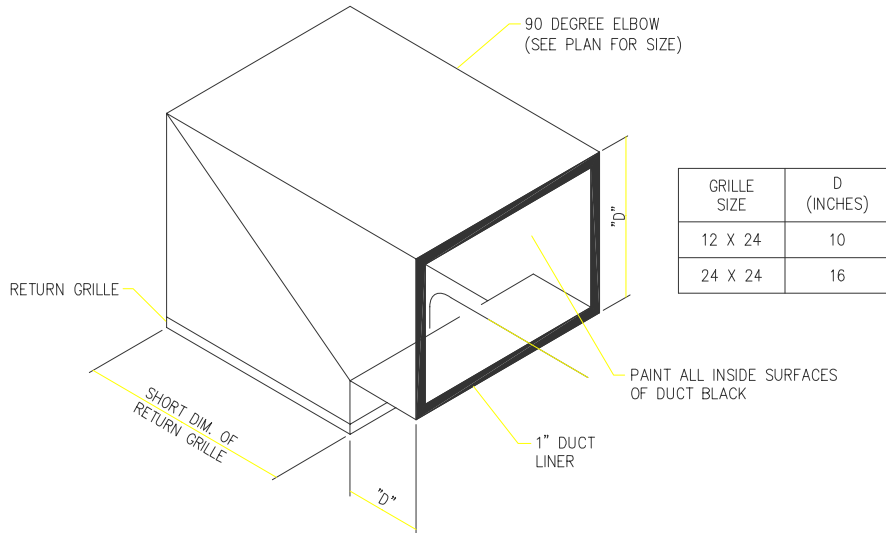

**SOUND BOX DETAIL**

NO SCALE

- 4.4. Sheet M1.1
- a. EH-1 to be Markel electric wall heater model 3420, 3.0 KW
- 4.5 Specifications: Section 15290
- a. Clarification: All rectangular supply and return ductwork shall be insulated with duct liner. All round supply ductwork shall be insulated with duct wrap .

**END OF ADDENDUM THREE**